

VESTAPOMP
Makes life comfortable

SDS / SNK

FIRE PUMPS



Who UL is and What UL Does

- UL (Underwriters Laboratories Inc.) is a global independent safety science company offering expertise across five key strategic businesses: Product Safety, Environment, Life & Health, University and Verification Services. Since the year UL founded in 1894, nearly 70,000 manufacturers in 100 countries have produced 100.000 different types of totally 22 billion UL Marked products.
- UL engineers scientifically investigate and test thousands of types of products, materials, constructions and systems to evaluate the electrical, fire and injury risks; the burglary or fire resistance; or the ability to detect, control or limit fires.
- UL has developed 1,600 Standards for Safety, which serve as the bedrock of compliance in over 200 industries.
- There is an “Online Certifications Directory” in UL’s website and all the products listed by UL can be found here.

UL Safety Standard: UL 448

- The requirements of this standard cover design and test features of centrifugal fire pumps intended for use in water-supply systems for fire-protection service.
- The pumps covered by these requirements are intended for installation and use in accordance with the Standard for the Installation of Stationary Pumps for Fire Protection, NFPA 20.

Who FM is and What FM Does

- FM (Factory Mutual) Global is one of the world’s largest business property insurers who also serves engineering solutions to be protected against basicly fire, natural disaster or other types of property risk.
- FM Approvals is a unit of FM Global who certifies industrial and commercial products and services for companies. When a product or service meets the standards of FM Approvals, it is issued the “FM APPROVED” mark to signify it will perform as expected.
- Currently there are 60.000 certified products and services and these are listed in “FM Approval Guide” which can be found in FM website.

FM Approvals Standard: 1311 / 1319

- FM Class 1311 states approval criteria for horizontal or vertical split case centrifugal fire pumps while FM Class 1319 states about horizontal end suction centrifugal fire pumps that supply water to fire protection systems.
- The requirements in these standards are mainly based on ANSI Hydraulics Institute (HI) and NFPA 20 standards.

General Information

Design Features According to UL & FM

• Only the specified capacities in the below table are allowed for rated capacity. For capacities higher than 5000 GPM, 500 GPM increments are allowed.

GPM	m ³ /h	GPM	m ³ /h	GPM	m ³ /h
25	5.68	400	90.8	2000	454
50	11.3	450	102.2	2500	568
100	22.7	500	113.5	3000	681
150	34.0	750	170	3500	795
200	45.4	1000	227	4000	909
250	56.8	1250	284	4500	1022
300	68.1	1500	341	5000	1136

- All interior bolt or screw that are exposed to pumped liquid shall be of rolled bronze or corrosion resistant material
- The pump shall be provided with automatic air-release valve, circulation relief valve and pressure gauges
- Bearings shall have an L-10 rating of not less than 5000 hours at maximum load.
- The pumps shall be provided with at least four packing rings plus a lantern ring. The lantern ring may be permitted to replace one ring of packing.
- Impellers, wear rings, shafts, lantern rings, glands shall be made of corrosion resistant material.
- Following material specifications are applied to UL/FM fire pumps:

Part List	Definition	DIN / EN		AISI / SAE / ASTM
Casing	Nodular Cast Iron	0.7040	EN-GJS-400-15 (GGG40)	A 536 60-40-18
Impeller	Cast Bronze	2.1050.01	G-CuSn 10	B427 C90700
Shaft	Stainless Steel	1.4021	X20 Cr 13	A 276 Type 420+QT
Shaft Seal	Stainless Steel	1.4404	X2 Cr Ni Mo 17-12-2	A 276 Type 316L
Wear Ring	Cast Bronze	2.1050.01	G-CuSn 10	B 427 C90700
Bolt & Screw	Stainless Steel	1.4301	X5 Cr Ni 18-10	A276 Type 304

Part List

001	Volute Casing
003	Stuffing Box
010	Support Foot
020	Wear Ring (back)
021	Wear Ring (front)
030	Bearing Housing
031	Bearing Bracket Lantern
034	Bearing Cover (outboard)
035	Bearing Cover (inboard)
042	Stuffing Box Gland
044	Lantern Ring
050	Impeller
060	Shaft
065	Impeller Nut
070	Shaft Protecting Sleeve
088	Thrower
200	Ball Bearing
210	Impeller Key
211	Coupling Key
212	Sleeve Key
230	Drain Plug
301	Stud+Nut+Washer
320	Hex. Head Bolt
321	Hex. Head Bolt
322	Hex. Head Bolt
323	Hex. Head Bolt
400	Stuffing Box Packing
405	Set Screw
410	Gasket
411	Gasket
420	O-Ring

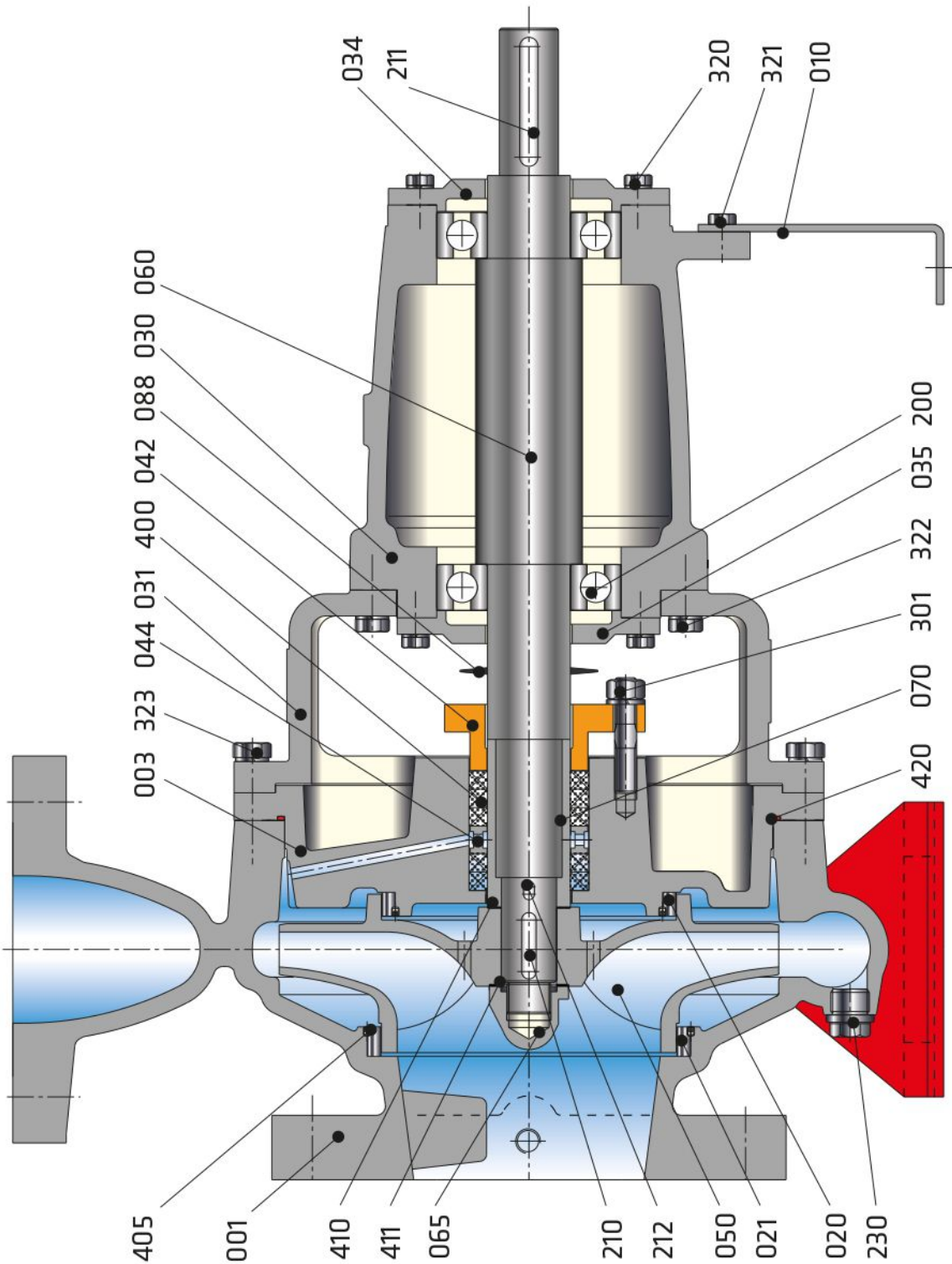

Selection Table



UL Listed & FM Approved Fire Pumps			
Pump Type	Capacity (GPM)	Pressure Range (PSI)	Speed (RPM)
SDS 65-250	100	102-171	3000
	150	100-171	3000
	200	100-171	3000
	250	99-171	3000
	300	98-171	3000
SDS 80-250	400	103-162	3000
	450	102-162	3000
	500	102-161	3000
SDS 80-315	500	173-208	3000
	750	167-204	3000
SDS 100-250	750	89-172	3000
	1000	85-171	3000
SDS 125-315	1250	117-199	3000
	1500	112-198	3000
	2000	130-192	3000
SDS 150-315	2000	92-125	2100
	2000	116-156	2350
	2500	87-123	2100
	2500	113-156	2350

UL Listed & FM Approved Fire Pumps			
Pump Type	Capacity (GPM)	Pressure Range (PSI)	Speed (RPM)
SNK 50-250	200	93-150	3000
	250	91-150	3000
	300	88-148	3000
SNK 65-250	300	92-142	3000
	400	88-142	3000
SNK 80-250	450	84-141	3000
	450	87-148	3000
	500	84-148	3000

(*) NOTE :

- Engines are rated at standard SAE conditions of 29.61 inches (752 mm) Hg barometer and 77°F (25°C) inlet air temperature [approximates 300 ft. (91.4 m) above sea level] by the testing laboratory (see SAE Standard J 1349).
- A deduction of 3 percent from engine horsepower rating at standard SAE conditions shall be made for diesel engines for each 1000 ft. (305 m) altitude above 300 ft. (91.4 m)